

# Mt. Angel School District #91

## FY2023 Cabling Infrastructure Solutions

SUBMIT PROPOSAL TO: Mt. Angel School District  
ATTN: Scott May  
PO Box 1129,  
Mt. Angel, OR 97362  
(503) 845-2345  
scott.may@masd91.org

---

Bidder (Company)

---

Address

City

State

Zip Code

---

Signature of member authorized to sign for firm (Title).  
(I certify that I have proposed according to the  
specifications and conditions of this proposal).

---

Doing Business under the Company Name of:

---

Telephone Number with area code

---

Facsimile Number with area code

Proposal must be submitted via email with subject line:  
**Proposal – FY23 Cabling Infrastructure Solutions**  
Include Vendor Contact name and address.

## SUPPORTING DOCUMENTATION

### Cabling Infrastructure

#### TABLE OF CONTENTS

Part I	GENERAL INFORMATION
Part II	REQUIRED INFORMATION
Part III	CRITERIA FOR SELECTION
Part IV	TIMELINE AND IMPLEMENTATION GUIDELINE

#### PART I - GENERAL INFORMATION

**I-1. Purpose.** This request for proposals provides interested parties with enough information to enable them to prepare and submit proposals for consideration by Mt. Angel School District to satisfy the District's need for cabling infrastructure.

**I-2. Issuing Office.** This supporting documentation is issued by Mt. Angel School District, ATTN: Scott May, PO Box 1129, Mt. Angel, OR 97362, (503) 845-2345, [scott.may@masd91.org](mailto:scott.may@masd91.org). **Email is the preferred method of communication.**

**I-3. Scope.** This supporting documentation contains instructions governing the proposals to be submitted and the materials to be included therein; a description of the service to be provided; requirements which must be met to be eligible for consideration.

## PART II - REQUIRED INFORMATION

### II-1 SCOPE AND DESCRIPTION

Mt. Angel School District seeks an estimated 70-75 network drops in 9 rooms and the hallway in a single school. The locations listed are approximate, and will be finalized during the mandatory walkthrough and quoting process. The breakdown of approximate drops per location are provided in the detailed table is below. Each location specifications are detailed in the associated appendix shown on the table below. This is an installation only proposal.

Proposals should include equipment, maintenance, installation cost and all applicable taxes and fees associated with such equipment. All cabling and hardware supplied must be new.

### II-2 SUMMARY OF CABLING

School	Address	Work to be Completed	Associated Document
St. Mary's Public School - North Hall	590 E. College St Mt. Angel, OR 97362	Network Drops: 42 drops  Ceiling Network Drops: 30	Appendix A

***\*Meeting location for walkthrough. Walkthrough is February 1, 2023 at 3:30 PM. Attendance confirmation is required. District contact for walkthrough is Scott May, 503.845.2345, [scott.may@masd91.org](mailto:scott.may@masd91.org) (preferred).***

### II-3 CABLING DETAIL (REQUIRED SPECIFICATIONS)

#### ***1. General infrastructure notes to for proposals to address***

- a. **Consult with district contact prior to beginning installation of new infrastructure**
- b. Cabling shall not be laid on ceiling grid structure, ceiling tiles or supported on any structure not specifically designed for supporting cables. If a cable tray is not present, provide cable supports at intervals of every 4-6 feet. Cable supports shall be "J" hooks or other supporting devices with a minimum 1-inch cable resting surface. Cable support devices shall be independently suspended from or

attached to building structure or walls. Cable sag between supports shall not exceed 12 inches. All cables shall be neatly bundled and secured with appropriately rated fasteners.

- c. Use “plenum” cable when required by national, state and local building code
- d. Use “outdoor-rated or direct burial” cable in any location exposed to the outdoor environment
- e. Use appropriate weather sealing and fire blocking to be installed where applicable

**f. All labels will follow district’s standard for labeling:**

- i. Patch panels will have clear labeling indicating Closet # and patch panel #
  - ii. Cables outer jacket will be clearly labeled on either end with an indelible ink fixed label or pen. Labeling will be located within 12 inches of termination.
  - iii. Surface mount jacks will be labeled using indelible ink machine labels (no hand-written labels)
    - 1. Labeling standard: NetworkCloset.PatchPanel.PortNumber
    - 2. Example: 01.02.34 which is Closet 01, Patch Panel 02, Port 34
  - iv. Verify drop labeling with district contact prior to labeling
- g. Install following cabling best practices, latest standards (listed below) for the type of cabling installing (Category 6), and manufacturer’s instructions (i.e. cabling lengths, proper support, bend radius, keeping wire twist, cable outer jacket not stripped back more than 0.5 inches, avoid EMI interference, tightness of cable ties, Velcro ties and not zip ties, etc.). Bidders must adhere to the following network cabling standards:
- i. ANSI/TIA:
    - 1. ANSI/TIA-568.0-D; ANSI/TIA-568.C.2
    - 2. ANSI/TIA-569-D
    - 3. ANSI/TIA-606-B
    - 4. ANSI/TIA-607-B
  - ii. BICSI - Telecommunications Distribution Methods Manual (most recent version)
    - 1. BICSI – Installation Transport Systems Information Manual
    - 2. BICSI – Network Design Reference Design Manual
    - 3. BICSI – Outside Plant Design Reference Manual
    - 4. BICSI – Electronic Safety and Security Design Reference Manual
  - iii. NFPA-70 - National Electric Code (Most recent version)
- h. Bidder is responsible for inspecting all existing structures, cableways, IDF/MDFs, wiring closets to determine if they are adequate for the purpose. Cableways must be utilized where available.

- i. Cables shall not be installed within 4-feet of transformers/motors. When running parallel to power conduits or fluorescent light fixtures maintain a 1 foot separation.

**j. Service Loop specifications:**

- i. Provide 4 ft. service loops above the wiring closet
  - ii. Provide 4 ft. service loops above ceiling on the remote wall mounted terminations
  - iii. Exceptions to these lengths will be when cable run (including patch cable) length would be greater than Ethernet cabling TIA/EIA-568-C standards allow. In these cases services loops can be adjusted as needed to fit within distance limitations.
- k. All parts used must be from a reputable manufacturer and be standardized across the project
- l. Each node must be properly terminated, tested and verified with appropriate documentation
- m. The bidder, including all subcontractors, must leave the premises clean and neat including having all ceiling tiles in place after the completion of the job or after individual work sessions if school will be in session soon after work has paused
- n. Bidder must supply all supervision, tools, equipment, hardware, material, transportation, and construction, and all other related services unless specific provisioning by the district has been denoted
- o. Bidder will be responsible for any additional or replacement cabling
- p. District lifts can be utilized by the contractors with prior notification

**2. General information**

**a. Contingencies**

- i. **All work and items are upon E-Rate funding and local funding**
  - ii. **Community Roots requires agreement by local building owner (school occupied portions of building are leased)**
- b. The school district reserves the right to award all, some or no portions of the project to a single or multiple bidders
- c. Work will need to be coordinated around school and class schedules
- d. On-site pre-bid walkthrough is required to bid on this project**
  - i. See above table for clarification
- e. Bidders must provide their USAC 498 ID (formerly known as a SPIN)
- f. Bids must include applicable permits, local, state, or federal permits, as necessary
- g. Bids must be itemized, separating out equipment provided and labor to install
- h. Bidders must agree to abide by current Oregon Prevailing Wage Rate Laws where applicable
  - i. [http://www.oregon.gov/boli/WHD/PWR/Pages/W\\_PWR\\_Covered.aspx](http://www.oregon.gov/boli/WHD/PWR/Pages/W_PWR_Covered.aspx)

- i. **All work and associated parts must be warrantied for a minimum of 1 year after completion of install**
- j. **Bidders will be licensed, bonded and insured to do business in the State of Oregon**
- k. **If bidder will use subcontractors they are required to disclose the contracting company**

**3. *Asbestos Containing Materials in Mt. Angel School District Buildings***

- a. Many of the District buildings have asbestos containing building materials in numerous locations which could be impacted during the course of this project. Contractor shall ensure that all staff have received Asbestos Awareness Training required to meet OSHA Standard 29CFR 1910.1001 and provide documentation of said training to owner.
- b. Prior to the start of work, owner's representative will hold a pre-construction meeting with Contractor to discuss types and locations of asbestos containing materials at that specific site, as well as procedures to follow in order to prevent the possibility of impact and fiber release episodes.
- c. Asbestos Containing joint compound and plaster in some of the wall systems have been found to contain asbestos fibers. Wall and ceiling penetrations at these locations will have to be marked by the contractor in advance so that School District trained personnel with HEPA Filtered equipment can cut them. Contractor will need to mark all necessary penetration areas at one time in advance, so that trained School District personnel can perform the necessary work as quickly and efficiently as possible in one site visit. Contractor's failure to do so may result in project delays due to lack of availability of District staff to make additional penetrations.

### **PART III - CRITERIA FOR SELECTION**

The proposals will be reviewed by Mt. Angel School District's Technology Team.

The following elements will be the primary consideration in evaluating proposals and in the selection of a Vendor

- 30%: Price of eligible products and services
- 25%: Compatibility with existing infrastructure and technology
- 20%: References including prior experience with vendor

- If we haven't worked directly with your company on a low voltage project within the last 5 years, please provide 3 references we can contact that contracted with your company, within the last 5 years, on projects of similar size and scope to this one.
- 15%: Warranty and support accessibility
- 10%: Local or in-state vendor

Questions may be submitted electronically via email to: [scott.may@masd91.org](mailto:scott.may@masd91.org); questions and responses will be posted in EPC and added to this RFP document.

Bids may be submitted via email to: [scott.may@masd91.org](mailto:scott.may@masd91.org)

Proposals must be sent to Mount Angel School District by the bid deadline specified in the narrative of the Form 470. Bidding will close after the E-Rate 470 allowable contract window, 28 days after form 470 submission. In the event that too few bids are received after the 28 day waiting window has ended, applicant may extend the bid deadline with appropriate notice to vendor(s). We reserve the right to reject late filed bids.

#### **PART IV - TIMELINE AND IMPLEMENTATION GUIDELINE**

All work must be completed prior to **September 30th, 2024 (pending USAC approval of application)**

# **APPENDIX A** – *St. Mary’s Public School South Hall/Front Entrance Network Wiring Upgrades*

## **1. Infrastructure to provide and install**

### **a. Network Drops**

- i. Approximately twenty (72) new Cat 6 data drops will be provided and installed
  1. See included map(s) for drop locations and counts. All locations are approximations.
- ii. Conceal exposed wiring in walls, conduit or wire molding (white) based on direction from district contact

### **iii. IC drops**

1. Drops are for future use (Appendix B) and will have a minimum of 4 feet spooled up on remote (non-network closet) end to allow flexible final installation location (further details to be provided during site walkthrough)

### **iv. WAP drops**

1. Existing WAP drops to be re-terminated to respective new, local IDFs or re-run as necessary
  - a. Keystone type (Cat 5e vs. Cat 6) to be clarified during site walkthrough

### **b. Existing Cabling**

- i. Our goal is to remove the old network cabling from the school and replace with Cat 6 or better.
- ii. If existing cabling is inadequate, it is to be removed.

### **c. Keystones & Wall Plates**

#### **i. Wall Drop Keystones:**

1. Leviton eXtreme QuickPort Jack, Cat 6, White or equivalent

#### **ii. New Wall faceplates:**

1. Appropriate (based on drop count) Leviton white keystone wall plates or equivalent

#### **iii. Access Point Drop Keystones:**

1. Leviton eXtreme QuickPort Jack, Cat 6, Yellow or equivalent

#### **iv. IC Drop Keystones:**

1. Leviton eXtreme QuickPort Jack, Cat 6, White or equivalent



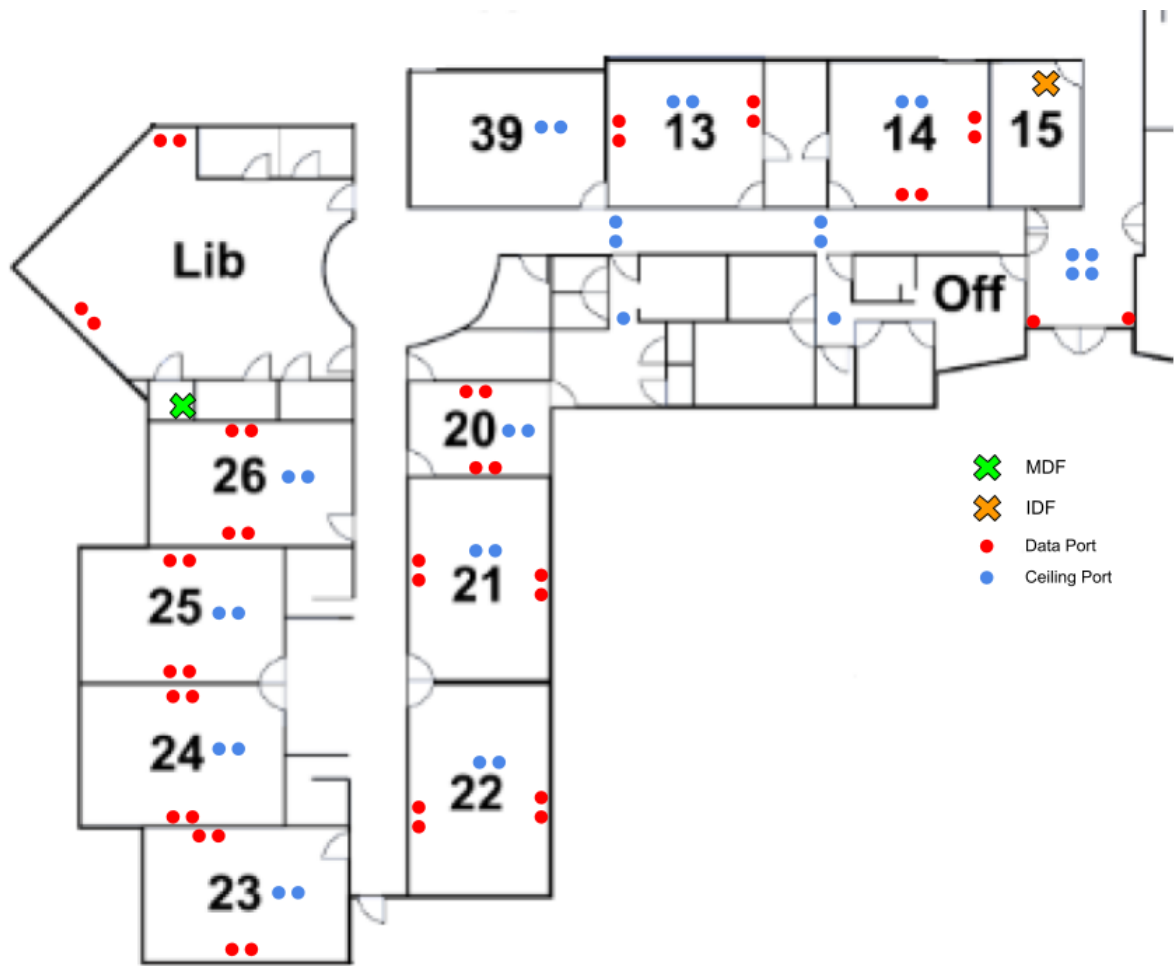

- ✕ MDF
- ✕ IDF
- Data Port
- Ceiling Port